

MiniFlex[®] MA110

MiniFlex[®] MA130















Flexible AC current sensors

ENGLISH

Thank you for purchasing an **MiniFlex® MA110 or MA130** flexible current sensor.

For best results from your instrument:

- **read** these operating instructions carefully,
- **comply** with the precautions for use.

	WARNING, risk of DANGER! The operator must refer to these instructions whenever this danger symbol appears.
	WARNING, risk of electric shock. The voltage applied to parts marked with this symbol may be hazardous.
	Equipment protected by double insulation.  Earth.
	Application or withdrawal authorized on conductors carrying dangerous voltages. Type B current sensor as per IEC 61010-2-032.
	Battery.  Direction of the current.
	The product is declared recyclable following an analysis of the life cycle in accordance with standard ISO14040.
	Chauvin Arnoux has adopted an Eco-Design approach in order to design this appliance. Analysis of the complete lifecycle has enabled us to control and optimize the effects of the product on the environment. In particular this appliance exceeds regulation requirements with respect to recycling and reuse.
	
	The CE marking indicates conformity with European directives, in particular LVD and EMC.
	The rubbish bin with a line through it indicates that, in the European Union, the product must undergo selective disposal in compliance with Directive WEEE 2002/96/EC.

Definition of measurement categories:

- Measurement category IV corresponds to measurements taken at the source of low-voltage installations. Example: power feeders, counters and protection devices.
- Measurement category III corresponds to measurements on building installations. Example: distribution panel, circuit-breakers, machines or fixed industrial devices
- Measurement category II corresponds to measurements taken on circuits directly connected to low-voltage installations. Example: power supply to electro-domestic devices and portable tools.

PRECAUTIONS FOR USE

The MA110 is protected against voltages up to 600 V with respect to earth in measurement category IV, or 1000 V in category III. The MA130 is protected against voltages up to 600 V with respect to earth in measurement category III. The protection assured by the current sensor can be compromised if it is used in a way that is not recommended by the manufacturer.

- Comply with the rated maximum voltage and current and the measurement category.
- Never exceed the protection limits stated in the specifications.
- Comply with the conditions of use, that is to say temperature, humidity, altitude, degree of pollution and location of use.
- Do not use the instrument if it is open, damaged, or incorrectly reassembled. Before each use, check the integrity of the insulation on the coil, the leads, and the electronic unit.
- The application or withdrawal of the sensor on uninsulated conductors at dangerous voltages requires the use of suitable safety equipment.
- If it is not possible to power down the installation, follow safe operating procedures and use suitable means of protection.
- All troubleshooting and metrological checks must be done by competent, accredited personnel.

CONTENTS

1. PRESENTATION	26	4. MAINTENANCE	41
1.1. General	26	4.1. Cleaning	41
1.2. Single-phase MiniFlex®.....	26	4.2. Replacing the batteries.....	41
1.3. Three-phase MiniFlex®	27	5. WARRANTY	42
2. CURRENT MEASUREMENT	28	6. TO ORDER	43
2.1. Measurement principle	28	6.1. Accessories and spares.....	43
2.2. Use	28	6.2. Specific models	44
2.3. Mains adapter (option).....	32		
3. CHARACTERISTICS	34		
3.1. Reference conditions.....	34		
3.2. Electrical characteristics	34		
3.3. Variations in the range of use	35		
3.4. Typical frequency response curves	36		
3.5. Frequency limitation as a function of amplitude	38		
3.6. Power supply	38		
3.7. Environmental conditions	39		
3.8. Construction specifications.....	39		
3.9. Conformity to international standards.....	40		
3.10. Electromagnetic compatibility (CEM)	40		

1. PRESENTATION

1.1. GENERAL

MiniFlex® sensors take the form of a flexible coil connected by a shielded lead to a housing containing the signal processing electronics, powered by batteries.

The flexibility of the sensors facilitates the clamping of the conductor to be measured, whatever its nature (cable, bar, strand, etc.) and its accessibility. The design of the coil opening and closing device, by snap locking, allows handling while wearing protective gloves.

The electronic unit can be connected to the mVAC or VAC input of a measuring instrument having an input impedance of $\geq 1\text{ M}\Omega$.

1.2. SINGLE-PHASE MINIFLEX®

MiniFlex® series MA110 single-phase sensors constitute a line of three models, 17, 25, and 35 cm long, that convert alternating currents ranging from 3 to 3000 A into proportional AC voltages.

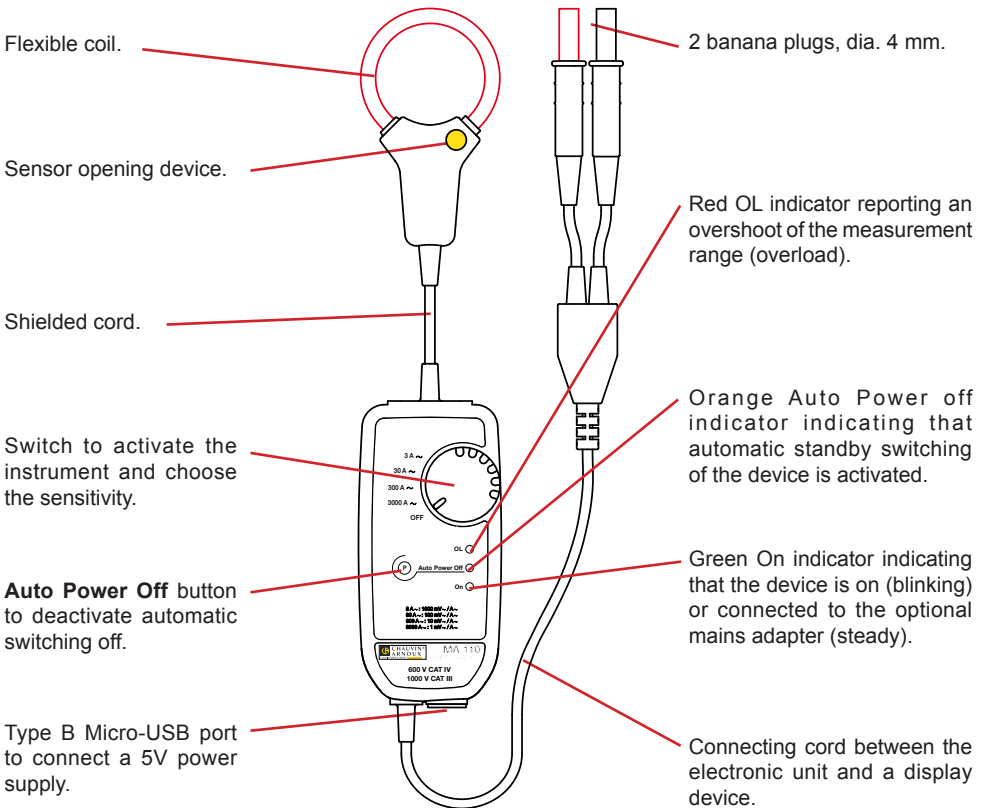

1.3. THREE-PHASE MINIFLEX®

The MiniFlex® series MA130 sensor converts alternating currents ranging from 30 to 3000 A into proportional AC voltages. It comprises 3 sensors 25 cm long connected to the electronic unit. The output is via 3 BNC connectors on which it is possible to place the adapters provided in order to obtain outputs with 2 safety plugs.

The three outputs of the electronic unit can be connected to a standard wattmeter (as auxiliary inputs), to multimeters, to a recorder, etc.

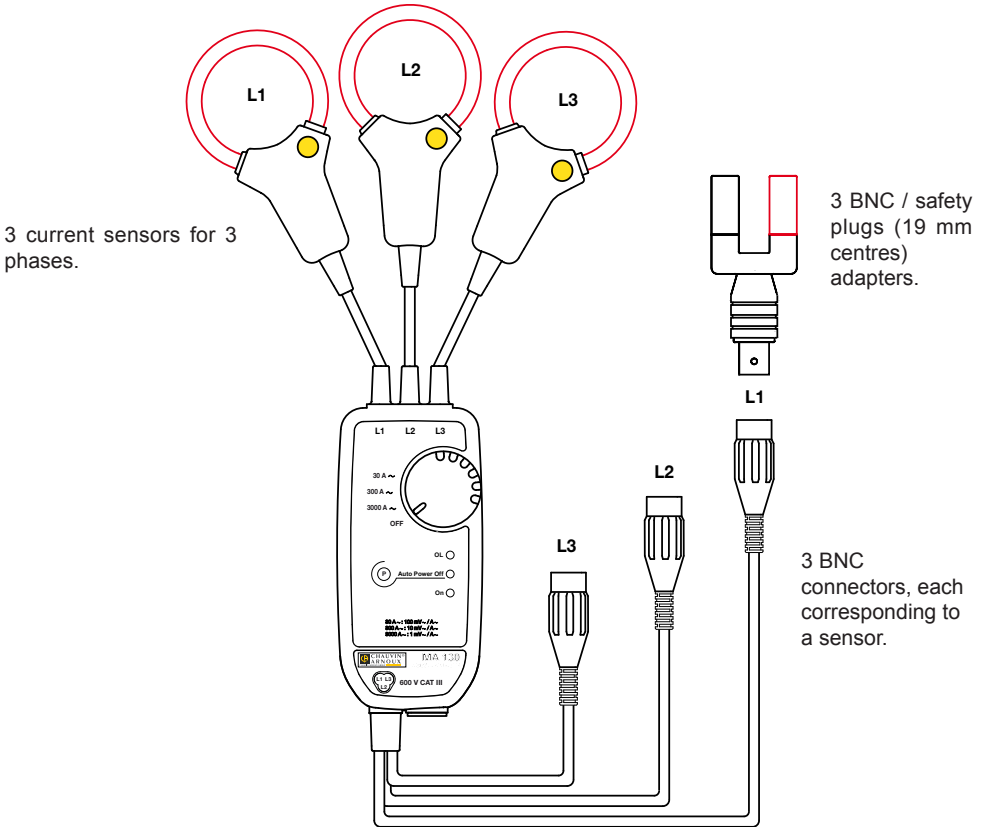

The multimeter or instrument connected must have a maximum voltage and a measurement category at least equal to those of the MiniFlex® sensor, since otherwise the maximum voltage and category of the assembly will be those of the lowest-rated component.

2. CURRENT MEASUREMENT

2.1. MEASUREMENT PRINCIPLE

The sensors use the principle of the Rogowski coil.

The sensor used achieves:

- very good linearity and no saturation effect (and so no overheating);
- a wide measurement dynamic, up to several kA;
- insensitivity to DC (measurement of the AC component of any AC + DC signal);
- light weight (no magnetic circuit).

2.2. USE

2.2.1. CONNECTING THE MA110

Connect the output leads to a measuring instrument having an input impedance $\geq 1\text{ M}\Omega$. Switch it on and set to AC voltage measurement.

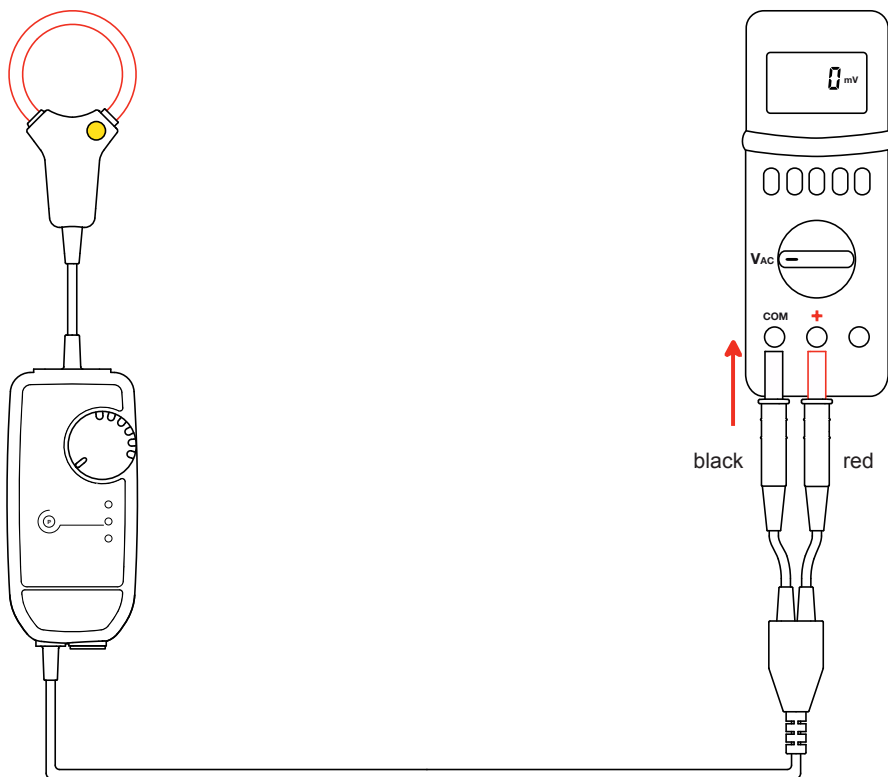

Put the electronic unit into operation by turning the switch to some position. The green **On** indicator starts blinking.



Press on the yellow opening device to open the flexible coil.

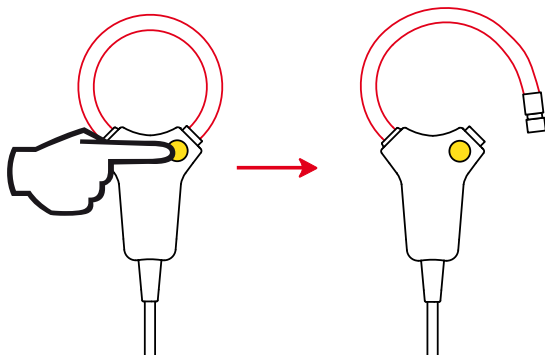

Open it and place it around the conductor carrying the current to be measured (only one conductor in the sensor). Close the coil. You must hear the “click”.



In the case of an uninsulated conductor at a dangerous voltage, use individual protection equipment.

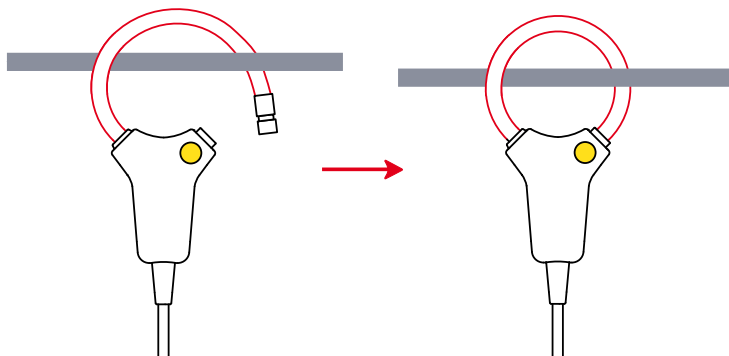

To optimize measurement quality, centre the conductor in the coil.

Set the switch of the electronic unit to the range providing the best sensitivity and check that the red **OL** indicator is off (saturation of the electronics entailing a measurement error).

Read the measurement on the multimeter, applying the reading coefficient indicated on the label on the electronic unit corresponding to the setting of the switch.

3 A~ range	1000 mV~/A~
30 A~ range	100 mV~/A~
300 A~ range	10 mV~/A~
3000 A~ range	1 mV~/A~

Multiply the reading by the coefficient.

For example, a reading of 1 V on the measuring instrument corresponds to a current of $\frac{1 \text{ V}}{10 \text{ mV/A}} = 100 \text{ A}$ in the 300 A~ range.

2.2.2. DISCONNECTING THE MA130

Withdraw the flexible coil from the conductor, set the switch to **OFF**, and disconnect the electronic unit from the multimeter.

2.2.3. IDENTIFYING THE SENSORS OF THE MA130

To identify the sensors and the output leads, you can mark them with the coloured rings provided with the device.

Clip rings of the same colour on the sensor and on the corresponding output leads.

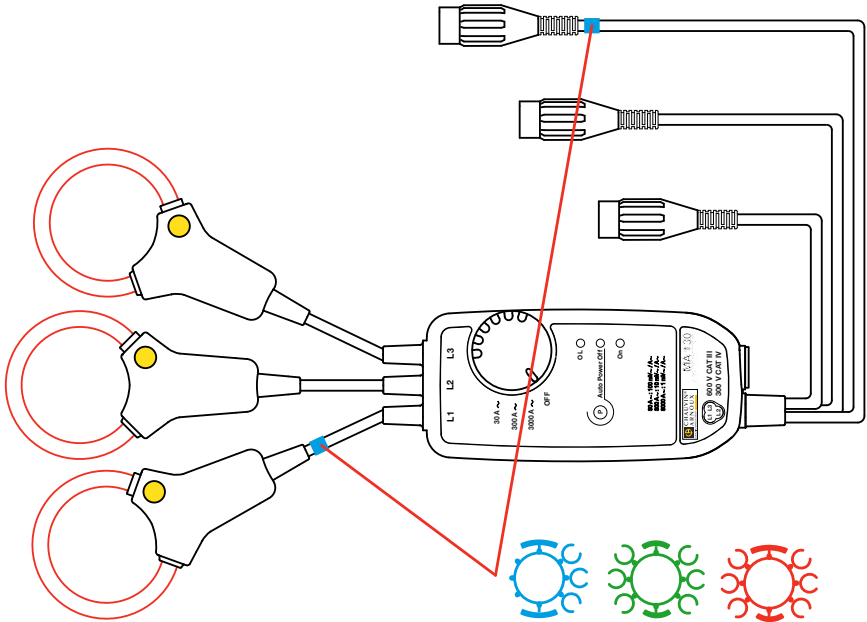

2.2.4. CONNECTING THE MA130

Proceed as for the MA110:

- Connect the output leads to a measuring instrument.
- Put the electronic unit into operation by turning the switch to some position. The green **On** indicator starts blinking.

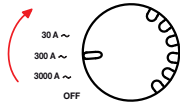

- Open the 3 sensors and place them on the 3 phases.

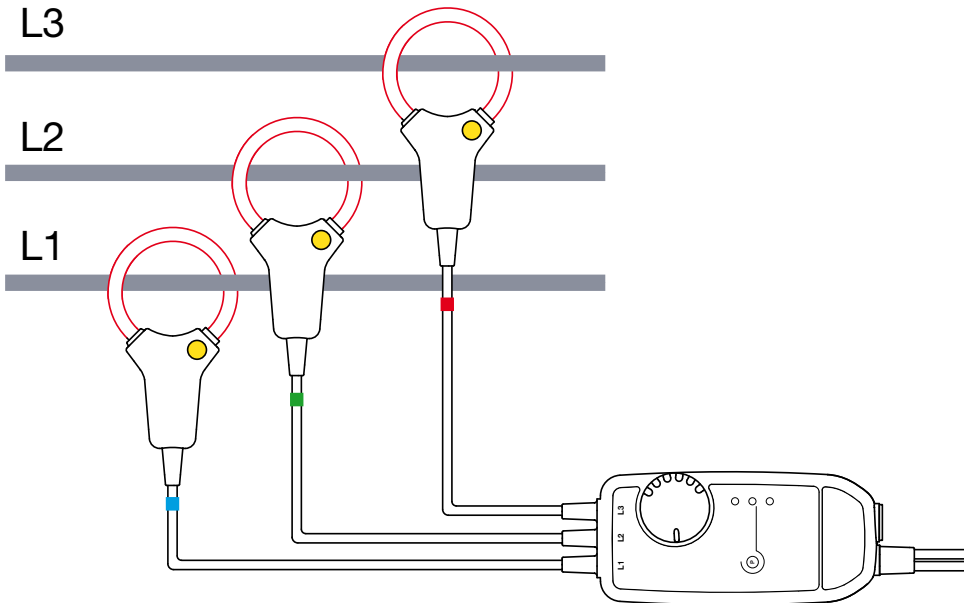

- Set the switch on the electronic unit to the range providing the best sensitivity and check that the red **OL** indicator is off (saturation of the electronics entailing a measurement error).
- Read the measurement on the display device and apply the reading coefficient indicated on the label on the electronic unit corresponding to the setting of the switch.

30 A~ range	100 mV~/A~
300 A~ range	10 mV~/A~
3000 A~ range	1 mV~/A~

2.2.5. DISCONNECTING THE MA130

Withdraw the 3 sensors from the 3 conductors, set the switch to **OFF**, and disconnect the electronic unit from the display device.

2.2.6. AUTOMATIC SLEEP MODE

When the device is started up, it operates for 10 minutes, then automatically switches itself to sleep mode in order to save the batteries.

To report that the automatic power off function is active, the orange Auto Power Off indicator is lit.



It is possible to override automatic power off. This is done by switching the device on by turning the switch to one of the measurement positions and at the same time pressing the Auto Power Off button for more than 2 seconds. The orange Auto Power Off indicator remains off.

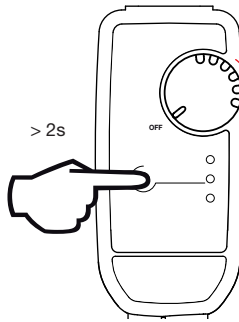

2.3. MAINS ADAPTER (OPTION)

For long-duration measurements, it is possible to connect the electronic unit to line power.

Withdraw the protection from the type B micro-USB connector, then connect the lead. You can use any mains/micro-USB adapter that delivers 100 mA or more.

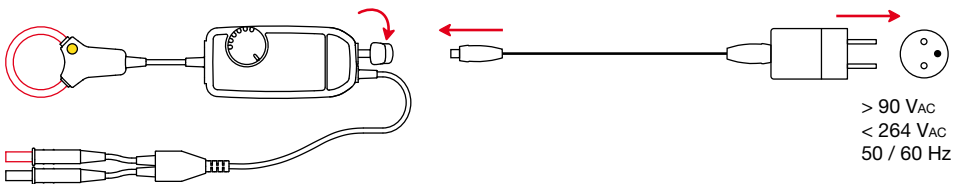

The green **On** indicator remains on but its brightness varies to indicate that the batteries are OK.

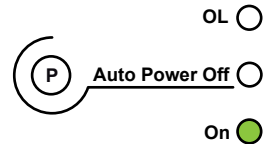

While the external power supply is present, automatic power off is disabled. But if the supply is cut off, the batteries take over and automatic power off acts at the end of 10 minutes.